

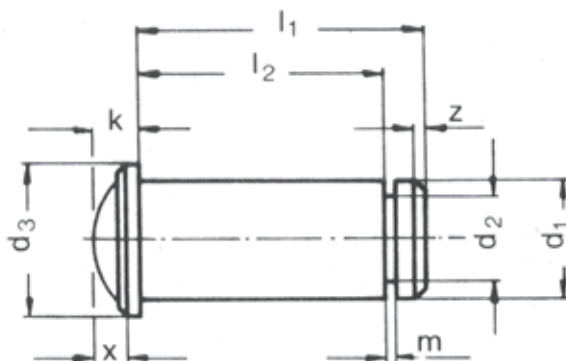

BEN-bult

För SL / KL bleck

För gaffelhuvud DIN 71752



Art-nr	Passar säkringsbleck*		Diam Ø d1 h11	Skalle Ø d3 h14	Längd		≈k	Ø d2 h11	m	z
	KL	SL			l1	l2				
BEN 4	4	4	4	6	10	8	1,5	3.2	0.640	0.500
BEN 5	5	5	5	8	12.5	10	1.5	3.2	0.740	0.500
BEN 6	6	6	6	9	15	12	2.5	5	0.740	0.750
BEN 8	8	8	8	12	19.5	16	2.5	6	0.940	1.000
BEN 10	10	10	10	14	24.5	20	3.5	8	1.050	1.000
BEN 12	12	12	12	17	29	24	3	9	1.150	1.250
BEN 14	14	14	14	18	32.5	27	3.5	10	1.250	1.250
BEN 16	16	16	16	20	38	32	3.5	12	1.350	1.500

Art-nr	Passande säkringsbleck*		d1 h11	Diam Ø d3	Skalle Ø l1	Längd l2	≈k	x	d2 h11	Ø m	z
	KL	SL									
BEN 18	16	-	18	23	42	36.5	3	1	13	1.350	1.500
BEN 20	24	-	20	26	46	40.5	4	1.5	17.5	1.800	1.500
BEN 25	24	-	25	32	57	50.5	5	2	18	1.800	1.500

* Se säkringsbleck SL och KL nästa sida.