

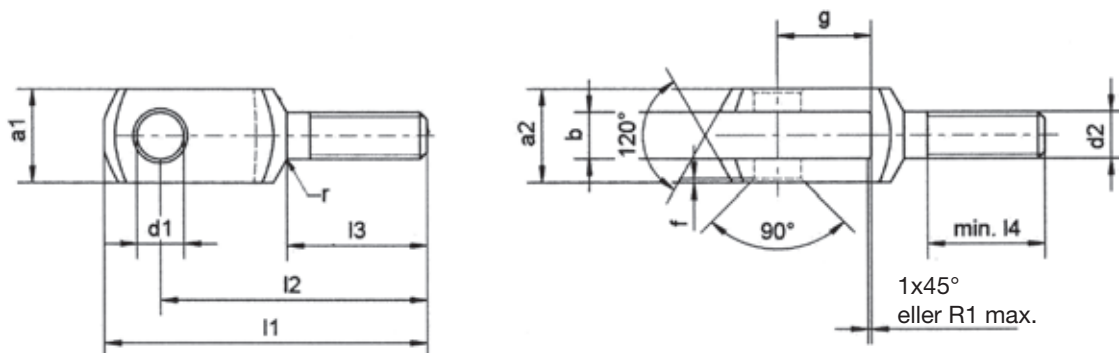

Gaffelhuvud

DIN 71752

Utvändigt gängad



Art-nr	d1	g	a12	a2	b	d2 ¹⁾		f	l1	l2	l3	l4	r ³⁾
	h9	+0.5	h11	+0.50 -20	+0.7 +0.15	Gänga	Fingänga	±0.2	±0.2	±0.4	±0.2	l4	
G 6x12 UG	6	12	12	12	6	M 6x1	—	0.5	44	37	20	15	0.8
G 8x16 UG	8	16	16	16	8	M 8x1.25	—	0.5	57	47	25	20	0.8
G 10x20 UG	10	20	20	20	10	M 10x1.5	—	0.5	69	57	30	25	0.8
G 12x24 UG	12	24	24	24	12	M 12x1.75	—	0.5	82	68	35	30	0.8
G 14x28 UG	14	28	27	24	14	M 14x2	—	1	94	78	40	35	1.2
G 16x32 UG	16	32	32	32	16	M 16x2	—	1	108	89	45	40	1.2
G 20x40 UG	20	40	40	40	20	M 20x2.5	—	1	134	109	55	50	1.5

Material: Stål 1.0718 (11SMnPb30+C).

Ytbehandling: El. förzinkat alternativt obehandlat eller rostfritt stål (X8CrNiS18-0)

Gaffelhuvud Med avlångt fästhål

DIN 71752

Art-nr	d1	d2 ¹⁾		b	a1	a2	l1	l2	l3	d3	g	f	l4
	±0.1	Gänga	Fingänga	+0.7 +0.1	h 11	±0.5 -0.2	±0.5	±0.4	±0.2	±0.2	±0.5	±0.2	±0.4
G 6x24 AH	6.2	M 6x1		6	12		43	36	9	10	2	0.5	12
G 8x32 AH	8.2	M 8x1.25		8	16		58	45	12	14	32	0.5	13
G 8x32 AH	8.2		M 8x1	8	16		58	48	12	14	32	0.5	16
G 10x40 AH	10.2	M 10x1.5		10	20		72	60	15	18	40	0.5	20
G 10x40 AH	10.2		M 10x1.25	10	20		72	60	15	18	40	0.5	20
G 12x48 AH	12.2	M 12x1.75		12	24		86	72	18	20	48	0.5	24
G 12x48 AH	12.2		M 12x1.25	12	24		86	72	15	20	48	0.5	24
G 14x56 AH	14.2	M 14x2		14	27		101	85	22.5	24	56	1	28
G 14x56 AH	14.2		M14x1.5	14	27		101	85	22.5	24	56	1	28
G 16x64 AH	16.2	M 16x2		16	32		115	96	24	26	64	1	32
G 16x64 AH	16.2		M 16x1.5	16	32		115	96	24	26	64	1	32

