

● Circular SAW Mountings



Features

The metal interleaf incorporated in (17-1392) the design provides a higher compression to shear stiffness ratio, thereby increasing the load capacity in the compression or combined compression and shear modes.

The 17-1780 engine mounting features a void in the rubber section to allow the use of a central snubber device.

Metalastik® type Circular SAW Mountings

Used in a variety of industrial applications including vibratory rollers and small screens or for the suspension of smaller type I.C. engines.

17-1780 can be fitted with a rebound washer for mobile applications.

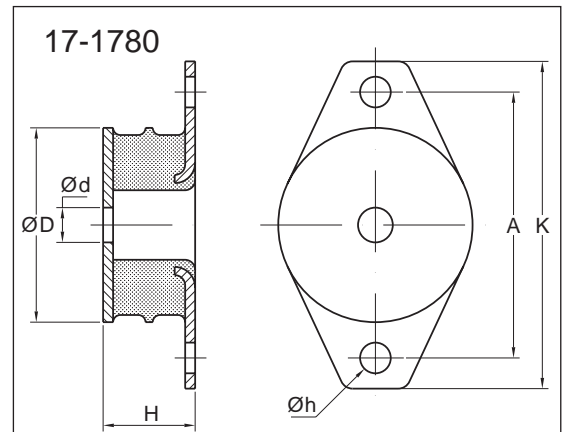
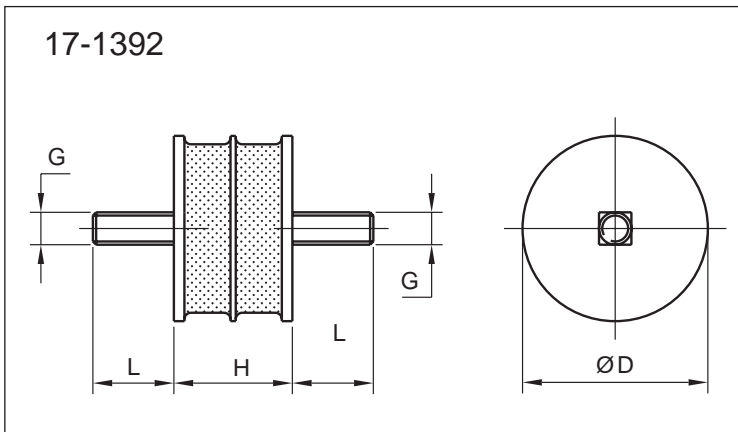

Type	Art.No.	Dimensions in mm						d	h	Max load in compression (kg)	Max load in shear (kg)	Weight (kg)
		D	H	L	G	A	K					
Circular SAW Mountings	17-1392-45 (45° IRH)	57	37	25	M10					120	90	0.28
	17-1392-60 (60° IRH)	57	37	25	M10					250	90	0.28
	17-1392-70 (70° IRH)	57	37	25	M10					330	90	0.28
	17-1780-45 (45° IRH)	95	45			130	160	17	15	190	135	0.81
	17-1780-60 (60° IRH)	95	45			130	160	17	15	380	160	0.81