



**Features**

Novibra® type SAW mountings consist of a cylindrical shaped rubber section with integrally bonded interleaf metal plates bonded to two square heavy duty outer metal fixing plates. Designed for large compressive forces with minimum deformation, while providing low shear stiffness rates.

The combination of a stable low installation height, high compressive strength and low shear stiffness makes Novibra® type SAW a versatile high performance antivibration mounting. Ease of installation due to 4 clearance holes in each fixing plate.

**Novibra® type SAW**

Novibra® elements type SAW are heavy duty mountings for static and shock loads in compression. Provides high isolation in the horizontal shear direction.

Typical fields of application are:

- Crushers
- Edge runners
- Mills
- Hoppers and feeders
- Grinders
- Vibratory rollers
- Screens
- Other very heavy machines and equipment

By connecting 2 SAW-elements in series, i.e. one on top of the other, an increased isolation efficiency is achieved in both shear and compression planes. Where larger deflections are required in the vertical plane, Novibra® type SAW mountings are mounted at a calculated angle configuration to provide the optimum spring rate.

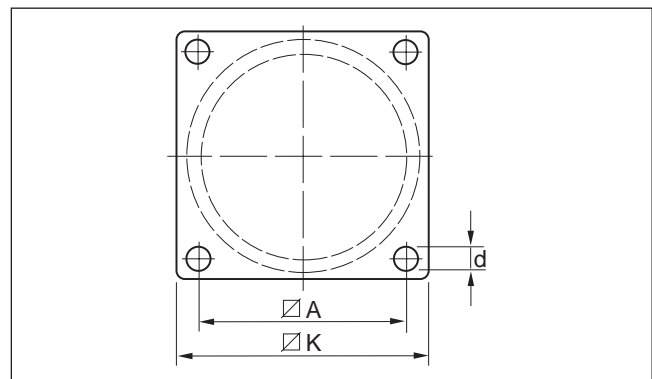
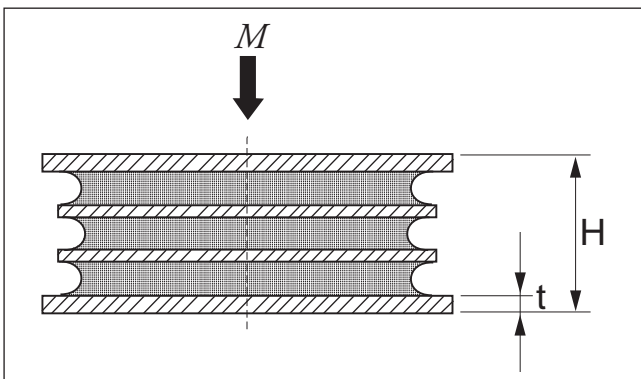
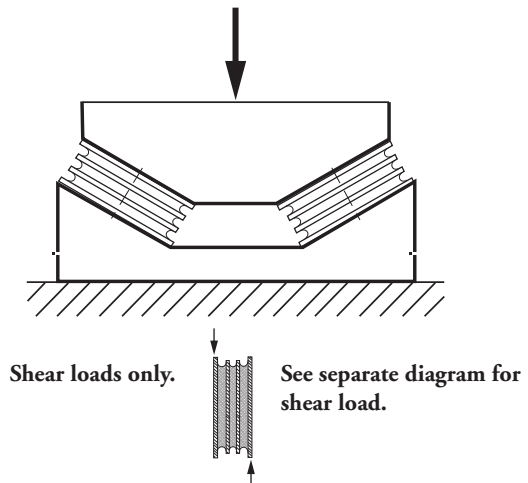

Type	Art.No. 40° IRH	Art.No. 60° IRH	Dimensions in mm					Weight (kg)	M-Max(kg)	
			A	K	H	d	t		40° IRH	60° IRH
SAW 125	2255130	2255140	118	148	52	13.5	5	2.6	2250	4500
SAW 150	2255150	2255160	136	166	63	13.5	6	4.1	3750	7500
SAW 200	814467	814475	184	220	82	17.0	8	9.2	6000	12000
SAW 300	814483	814491	270	310	120	22.0	10	27.0	15000	30000